

TECHNICAL FILE

Trademark:



Type: *W80*

Manufacturer: **COMER SpA**

42011 Bagnolo in Piano (RE) ITALY



FACTORY ORIGINAL PARTS ONLY ADMITED
ANY MATERIAL REMOVAL OR POLISHING IS FORBIDDEN
THE ENGINE MUST BE ORIGINAL

TECHNICAL INFORMATION

BORE	52	Fuel	- Mix. 5%
		Ignition	- Electronic "SELETTA"
STROKE	38	Clutch	- Centrifugal single piece
		Drive	- Sprocket T.11-12
CAPACITY	81 cc.	Carburettor	- Tillotson HL 166
		Cylinder	- NICASIL

STAMP AND SIGNATURE
(National Sporting Authority)

SQUISH MIN. 1mm
in the middle of the extent

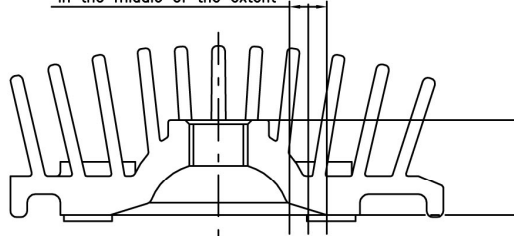

COMBUSTION CHAMBER
VOLUME 8.3cm Minimum
measured on the spark plug surface
using Shell oil Advance M mixed
with fuel 50%

PISTON RING

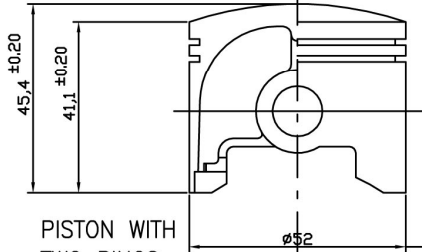
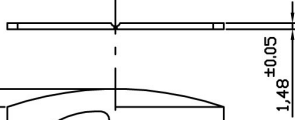

PISTON WITH
TWO RINGS

AA	- 52.01
A	- 52.00
B	- 51.99
C	- 51.98
D	- 51.97

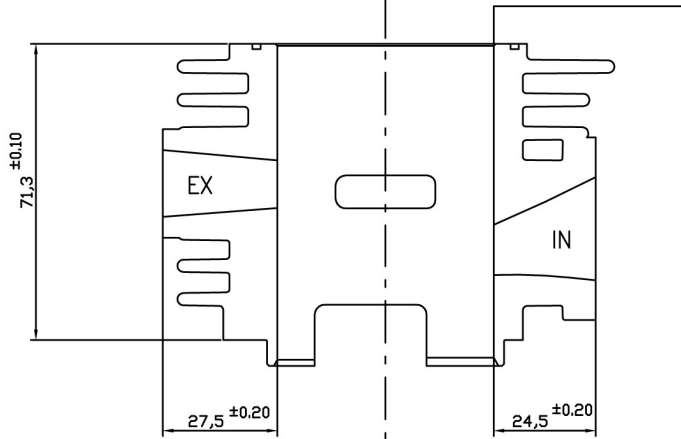
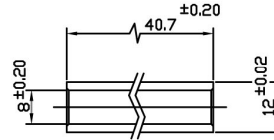

CYLINDER

AA	- 52.054-52.045
A	- 52.044-52.035
B	- 52.034-52.025
C	- 52.024-52.015
D	- 52.014-52.005

CRANKCASE SURFACE

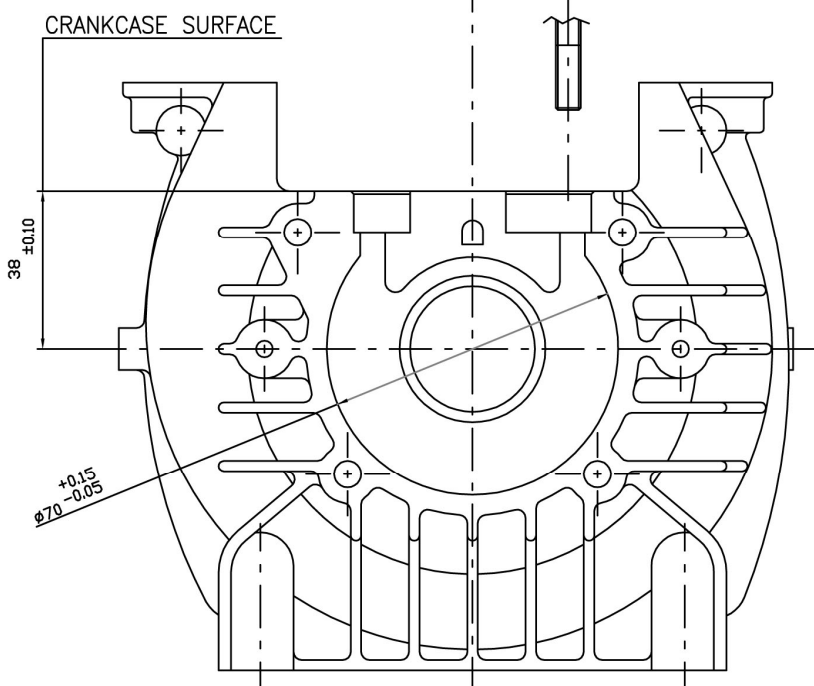

CRANKCASE SURFACE

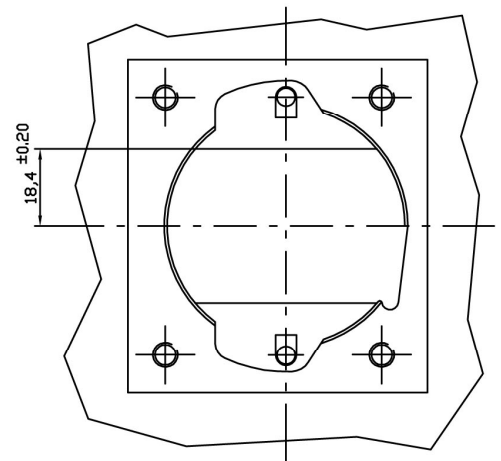

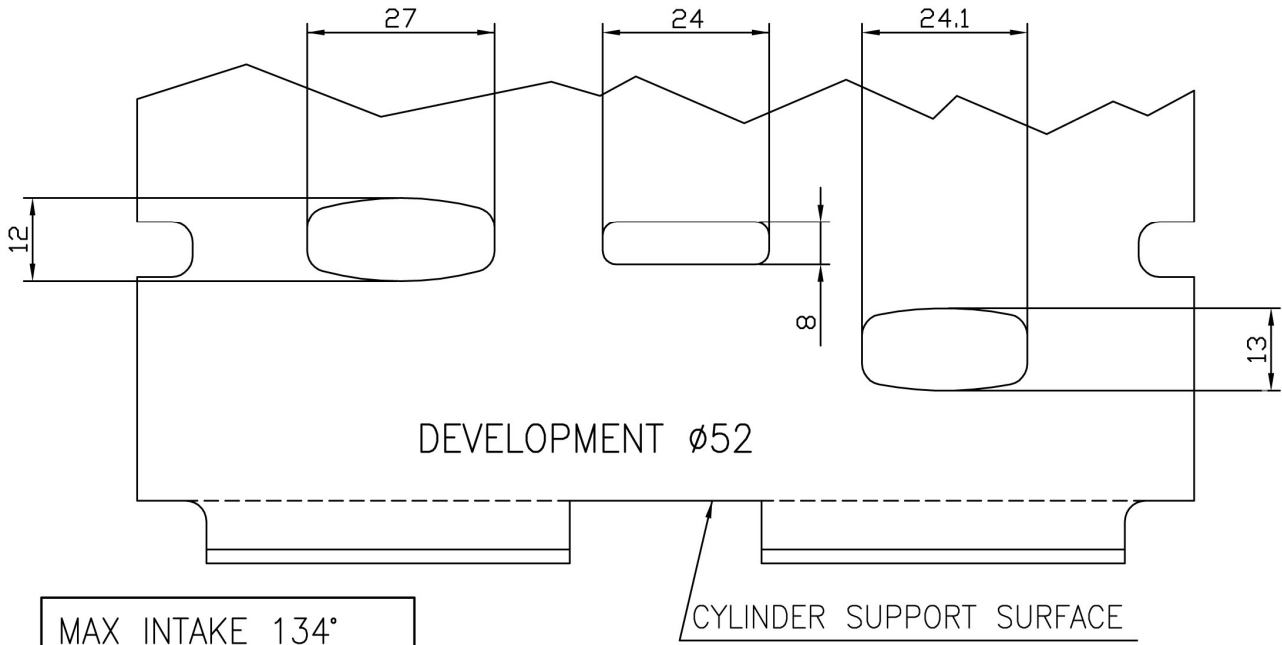

MAX INTAKE 134°
MAX EXHAUST 153°
MAX TRANSFER 124°

ALL MEASUREMENTS DONE WITH
0.2 FEELER GAUGE WIDE 8 mm

TOLERANCES ± 0.30 mm

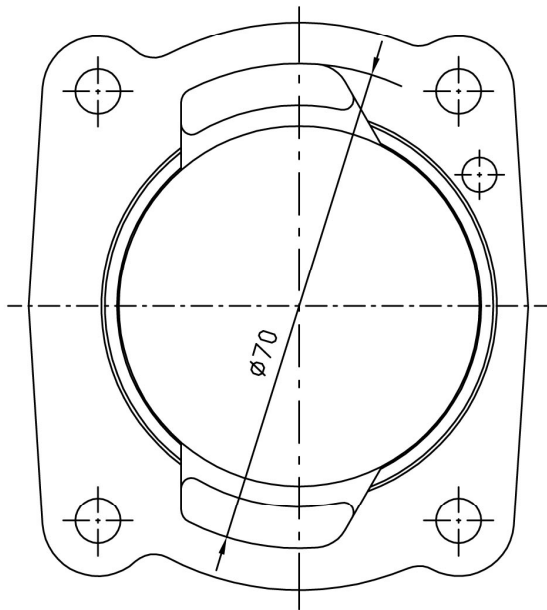

TOLERANCES ± 0.30 mm

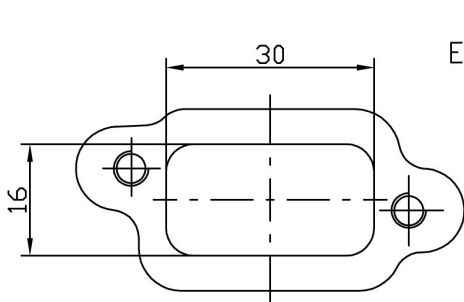
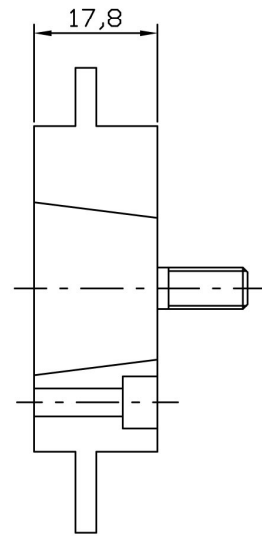

CYLINDER EXHAUST FLANGE

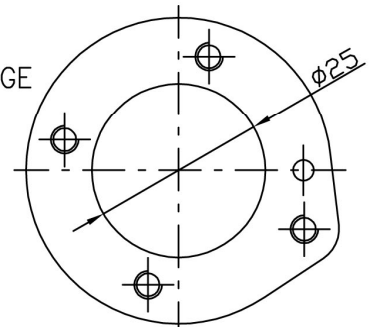

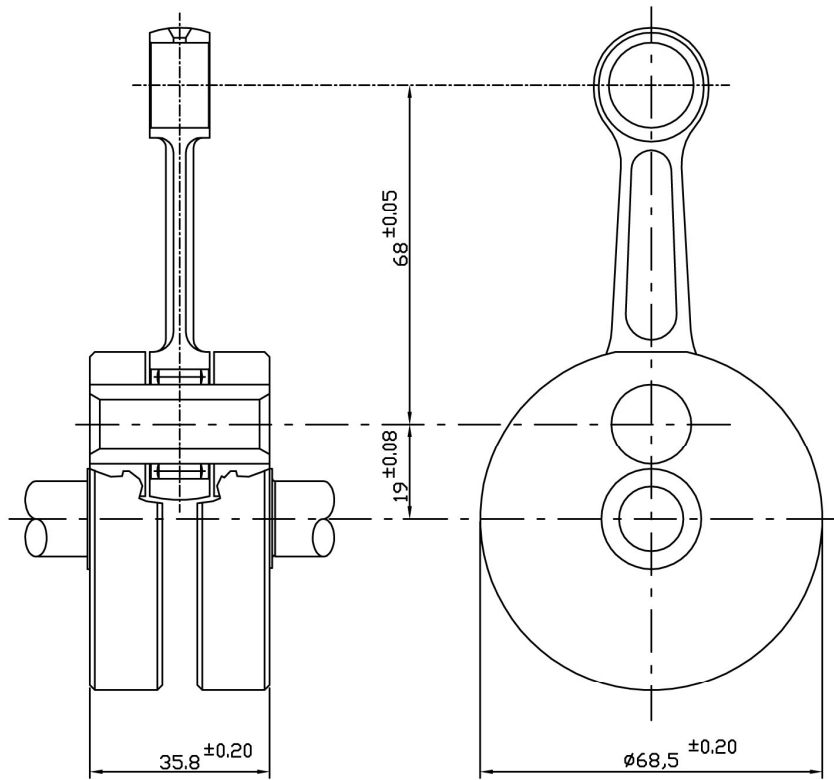

ORIGINAL ROLLER CAGES

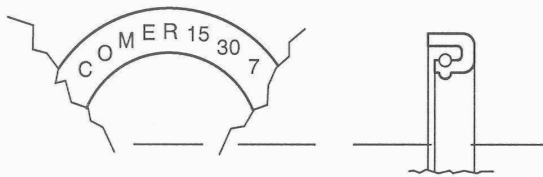

ORIGINAL OIL SEALS WITH SPRING
8 BALLS BEARING WITH IRON CAGE

ORIGINAL CARBURETTOR "TILLOTSON HL 166"

max. Venturi \varnothing 16 mm.

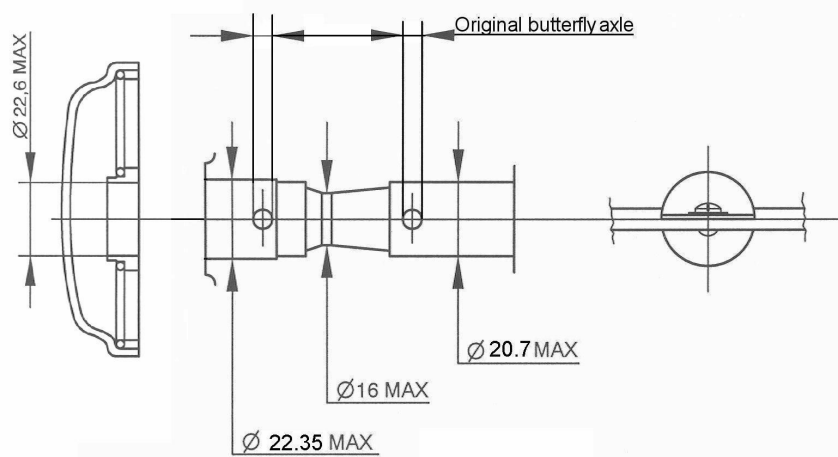

OPTIONAL

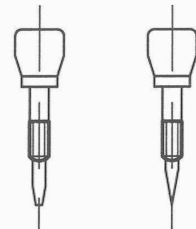

CLUTCH

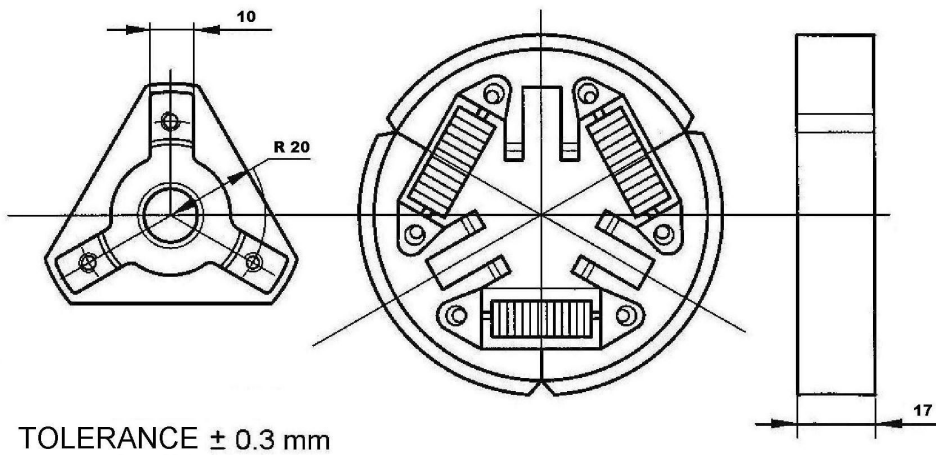

CLUTCH

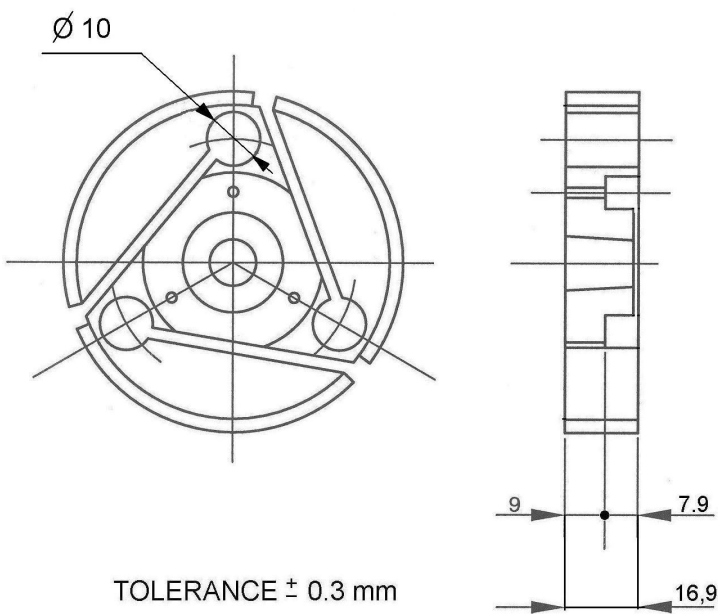

COMER SPROCKET
11-12 TEETH PITCH

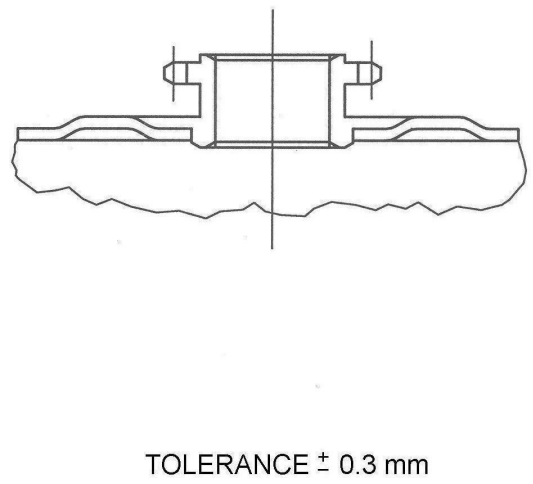

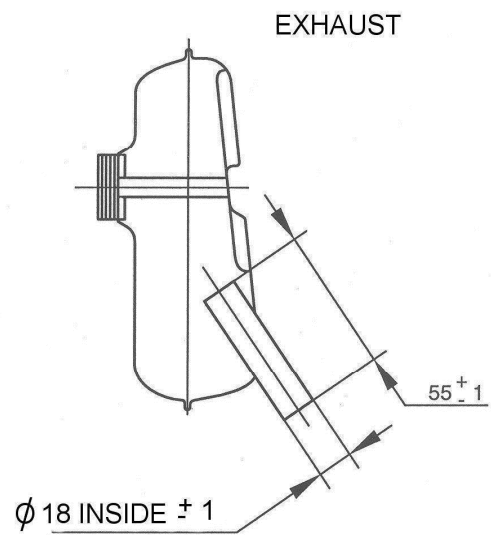

ELECTRONIC IGNITION

SELETTRA

RECOMENDED SPARK PLUGS:

BOSCH W2AS-W08AS

SPARK PLUG CAP

COMER ORIGINAL

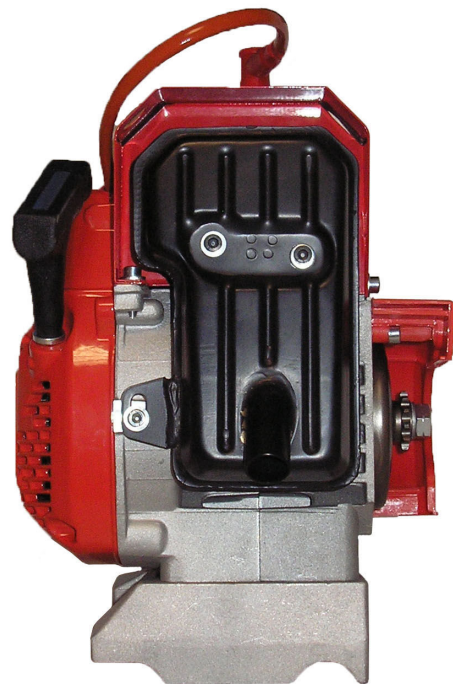
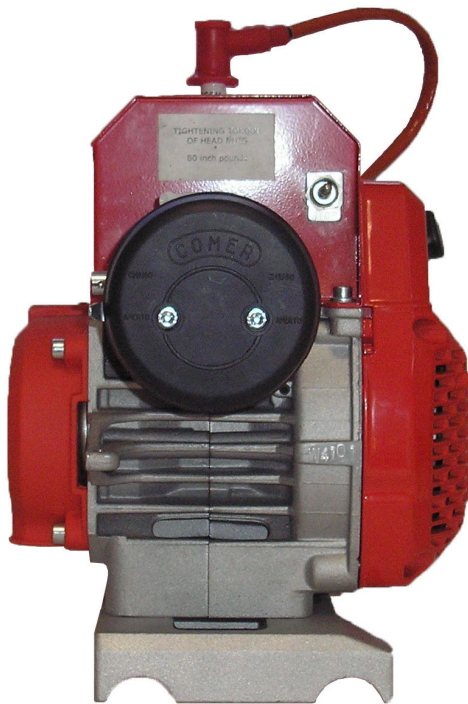
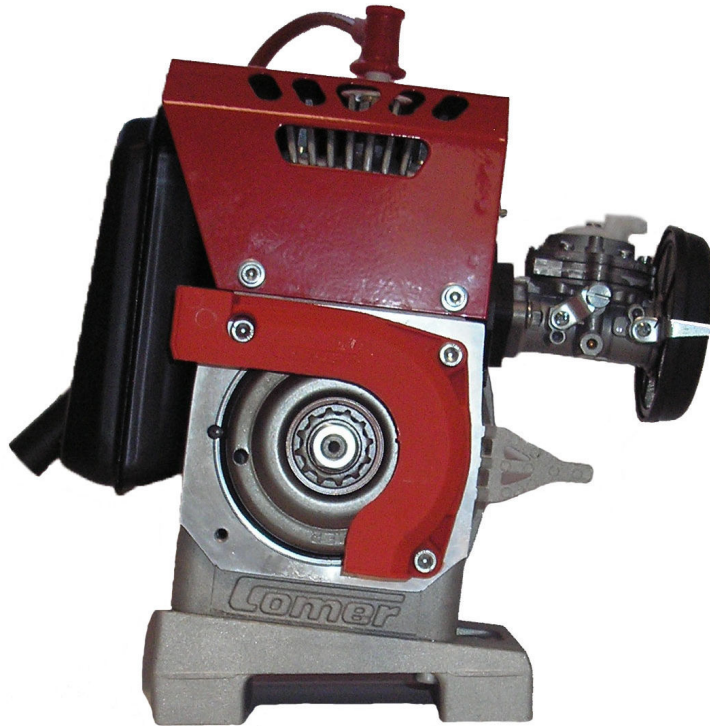

Comer S.p.A.

Via Storchi, 8 Loc.S.Tomaso 42011
BAGNOLO IN PIANO (RE) ITALY

0522/955044 FAX 0522/955040

www.comer-topkart.it